

VPE-078-T

Vibration transducer with integrated electronics

1. Assignment

Converting machine parts and tools vibrations into an electrical signal proportional to the vibration acceleration .

2. Applying

Automated control systems and regulation HPP, TPP, NPP, gas pumping stations. Stationary vibration measurement equipment for industrial facilities: steam turbines, generators, motors, pumps, fans. Systems of protection against vibration destruction.

3. Operating principle

Sensor element with a fixed type bending seismic mass body perceives vibration and generates an electrical signal proportional to the acceleration. The electrical signal is amplified by an electronic circuit.

The sensing element is made by diffusion welding. Includes a piezoceramic element, the electrical characteristics of which are thermostable. Vibration transducer VPE-078-T is manufactured according to TU U 32.1-14247566-001: 2005. Included in the State Register of measuring instruments permitted for use in Ukraine, the number U1955-15. Certificate of Compliance type of measuring technique № UA-MI / 2-5088-2015.

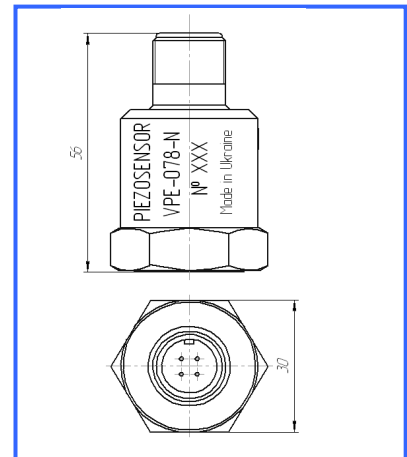

4. Specifications:

Parameter	Unit	Size
Sensitivity	мкА · м ⁻¹ · с ²	10
Deviation of sensitivity	%	≤ ±5
Measurement range	м/с ²	0,1 .. 100
Frequency response	Hz	10 .. 1000
Mounted base resonance	Hz	≥6000
Amplitude linearity	%	≤ ± 2
Unevenness frequency response	%	≤ ± 6
Coefficient of cross sensitivity	%	≤5
Operating temperature range	°C	0 .. 120
Error caused by the temperature range	%/°C	≤ ± 0,05
Bias voltage	B	7,5±0,5
Current range	мА	от 3 до 4
Electrical noise	мкА	≤0,08
Case isolation	Ом	≥ 10 ⁸
Sealing		IP 67
Weight	gms	≤200
Dimensions	мм	26x35x53
Case material		Stainless Steel
Mating connector	type	2PМГ14
Sensing element/construction		PZT/bending
Attachment		M6
Mounting torque	Нм	1,9 .. 2,1